



Designation: C832 – 21

# Standard Test Method for Measuring Thermal Expansion and Creep of Refractories Under Load<sup>1</sup>

This standard is issued under the fixed designation C832; the number immediately following the designation indicates the year of original adoption or, in the case of revision, the year of last revision. A number in parentheses indicates the year of last reapproval. A superscript epsilon ( $\epsilon$ ) indicates an editorial change since the last revision or reapproval.

## 1. Scope

1.1 This test method covers the procedure for measuring the linear change of refractory specimens that are subjected to compressive stress while being heated and while being held at elevated temperatures.

1.2 This test method does not apply to materials whose strength depends on pitch or carbonaceous bonds unless appropriate atmospheric control is used (see 7.3).

1.3 The values stated in inch-pound units are to be regarded as standard. The values given in parentheses are mathematical conversions to SI units that are provided for information only and are not considered standard.

1.4 *This standard does not purport to address all of the safety concerns, if any, associated with its use. It is the responsibility of the user of this standard to establish appropriate safety, health, and environmental practices and determine the applicability of regulatory limitations prior to use.*

1.5 *This international standard was developed in accordance with internationally recognized principles on standardization established in the Decision on Principles for the Development of International Standards, Guides and Recommendations issued by the World Trade Organization Technical Barriers to Trade (TBT) Committee.*

## 2. Referenced Documents

2.1 *ASTM Standards:*<sup>2</sup>

E691 Practice for Conducting an Interlaboratory Study to Determine the Precision of a Test Method

## 3. Terminology

3.1 *Definitions of Terms Specific to This Standard:*

3.1.1 *maximum dilation*—the percent expansion where the thermal-expansion rate equals the creep-deformation rate. It

<sup>1</sup> This test method is under the jurisdiction of ASTM Committee C08 on Refractories and is the direct responsibility of Subcommittee C08.01 on Strength.

Current edition approved Aug. 1, 2021. Published August 2021. Originally approved in 1976. Last previous edition approved in 2021 as C832 – 00 (2021). DOI: 10.1520/C0832-21.

<sup>2</sup> For referenced ASTM standards, visit the ASTM website, www.astm.org, or contact ASTM Customer Service at service@astm.org. For *Annual Book of ASTM Standards* volume information, refer to the standard's Document Summary page on the ASTM website.

can be used in estimating thermal-expansion relief when used in conjunction with the temperature at maximum dilation.

3.1.2 *temperature at maximum dilation*—in addition to estimating thermal-expansion relief, it can be used to rank products in terms of relative refractoriness. In general, the higher the temperature at maximum dilation, the more refractory the product and the better it is able to resist deformation at elevated temperatures.

3.1.3 *20 to 50 h creep*—the percent deformation between the 20 and 50 h can be used to rank products in terms of relative load-bearing capacity at a particular temperature. Relative rankings of various products may differ at different temperatures.

## 4. Summary of Test Method

4.1 Test specimens sawed from samples of refractory brick or from prefabricated samples of monolithic refractories are placed in a furnace and subjected to a prescribed compressive stress. Sensors are positioned for continuously measuring the linear change of the specimens parallel to the direction of the compressive stress. The temperature and linear change of the specimens are continuously recorded while heating the furnace at a controlled rate for thermal expansion under load testing. The time and linear change of the specimens are also continuously recorded while at soak temperature for 20 to 50 h of creep testing.

4.2 The user should be aware that other mechanisms, besides those related to creep, may be activated. This is especially true as temperatures approach 3002 °F (1650 °C). When other material responses are activated, such as corrosion, oxidation, sintering, etc., strong caution should be exercised when interpreting and identifying creep mechanisms.

4.3 Since materials tend to exhibit faster creep rates during the initial stage of deformation, the user should be cautioned when extrapolating measured creep rates beyond the normal 50 h test time. The material must be in the secondary creep stage in order to extrapolate to longer times.

## 5. Significance and Use

5.1 The thermal expansion under load and the 20 to 50 h creep properties of a refractory are useful in characterizing the

load-bearing capacity of a refractory that is uniformly heated. Directly applicable examples are blast furnace stoves and glass furnace checkers.

**6. Interferences**

6.1 *Chemical Interactions with Test Environment*—The test environment (vacuum, inert gas, ambient air, etc.), including moisture content (percent relative humidity), may have a strong influence on both creep strain rate and creep rupture life. In particular, refractories susceptible to slow crack growth or oxidation will be strongly influenced by the test environment. Testing should be conducted in environments that are either representative of service conditions or inert to the refractories being tested, depending on the performance being evaluated.

6.2 *Specimen Surface Preparation*—Surface preparation of specimens can introduce machining flaws that may affect the creep strain rate and creep rupture life. Machining damage imposed during specimen preparation will most likely result in premature failure of the specimen, but may also introduce flaws that can grow by slow crack growth. Surface preparation can also lead to residual stresses, which can be released during the test.

6.3 *Specimen/Extensometer Chemical Interactions*—If the strain measurement technique relies on physical contact between the extensometer components (contacting probes or optical method flags) and the specimen, then the flag attachment methods and extensometer contact materials must be chosen with care to ensure that no adverse chemical reactions occur during testing. This should not be a problem if the probe or specimen materials are mutually chemically inert. The user should also be aware that impurities or second phases in the probes and flags or specimens may be mutually chemically reactive and could influence the results.

6.4 *Temperature Variations*—Creep strain is related to temperature through an exponential function. Thus, fluctuations in test temperature or changes in temperature profile along the length of the specimen can cause fluctuations in strain measurements or changes in creep rate (see 7.1 and 7.2).

**7. Apparatus**

7.1 *Electrically Heated Furnace*, with a setting space sufficient to contain one or more specimens of the size specified in Section 8. The specimens should be equally heated on at least two opposite sides, and the temperature difference between specimens in a multiple-position furnace and between the top and bottom ends of single specimens should be no more than 18 °F (10 °C). See Figs. 1-5 for sketches of five typical furnace arrangements.

7.2 *Temperature Controllers*, that control heating at a rate of  $100 \pm 9 \text{ }^\circ\text{F/h}$  ( $55 \pm 5 \text{ }^\circ\text{C/h}$ ) over the temperature range from 500 to 3000 °F (260 to 1650 °C) and can control soak temperatures within  $\pm 9 \text{ }^\circ\text{F}$  ( $\pm 5 \text{ }^\circ\text{C}$ ).

7.3 *Air Atmosphere*, unless otherwise specified. If pitch or carbonaceous-bonded materials are tested, specify the atmosphere used when reporting results.

7.4 *Linear Measuring Device*, that records the difference in length dimension of each specimen parallel to the direction of stress and yields the desired precision and reproducibility.

7.5 *Recorders*, that display linear change readings to  $\pm 0.0005 \text{ in.}$  (0.013 mm).

7.6 *Loading Devices*, that apply at least 100 psi (689 kPa) compressive stress within  $\pm 1 \%$ , on a 1½ by 1½-in. (38 by 38-mm) cross section.

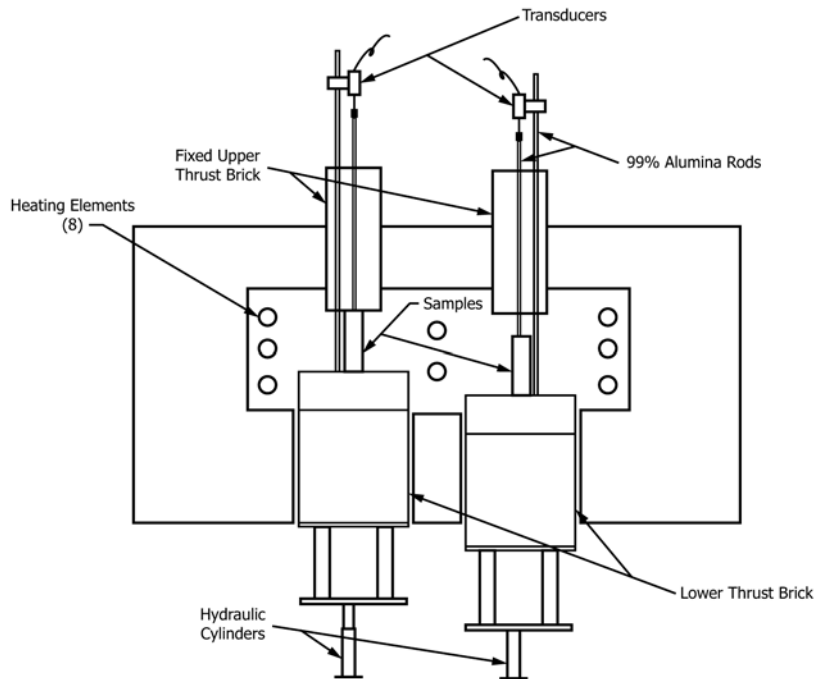

**FIG. 1 Specimen Furnace Arrangement**

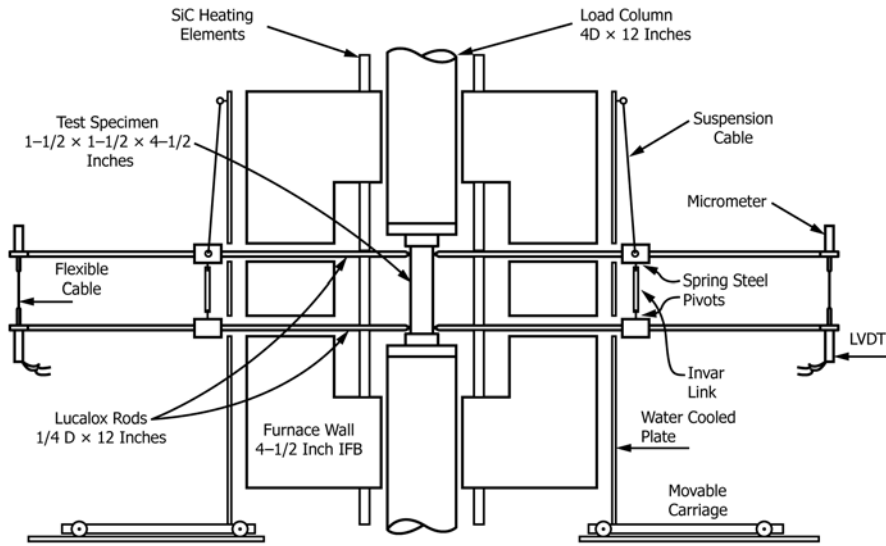

FIG. 2 Specimen Furnace Arrangement

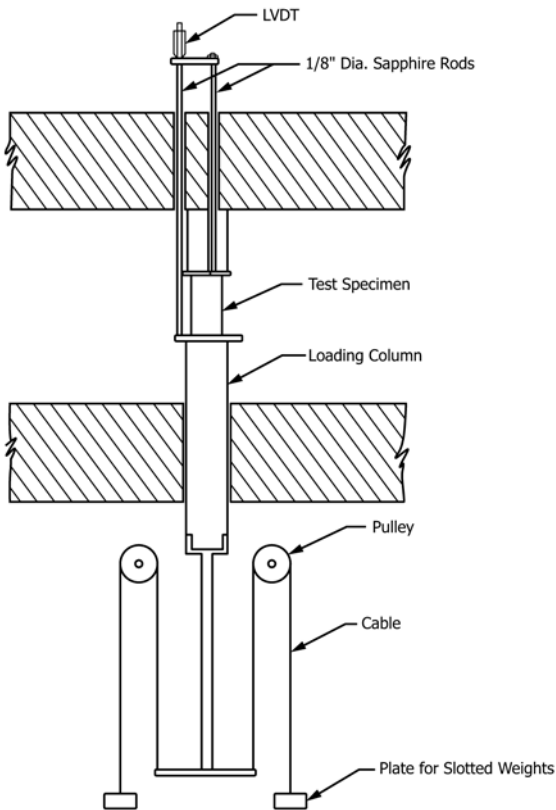

FIG. 3 Specimen Furnace Arrangement

## 8. Specimen Preparation

8.1 Cut or form specimens nominally 1½ by 1½ by 4½ in. (38 by 38 by 114 mm) (Note 1) with the 4½-in. dimension perpendicular to the pressing direction of a brick, the ramming direction of a plastic, or the position of the vibrator used in forming a castable. The 4½-in. dimension may be parallel to the length or width of the original shape.

NOTE 1—Specimens of different geometry (for example, cylindrical) may be used upon agreement between the parties concerned.

8.2 Grind or sand both 1½ by 1½-in. (38 by 38-mm) surfaces so that they are nominally plane and perpendicular to the length dimension. The parallelness tolerance on the loading surfaces of the specimen is recommended to be within 0.001 in. (0.03 mm). Only the 1½ by 1½-in. (38 by 38-mm) and one 1½ by 4½-in. (38 by 114-mm) surfaces may be original.

8.3 Measure all dimensions to the nearest 0.001 in. (0.03 mm) as follows:

8.3.1 *Length*—Average five measurements which include four taken at ¼ in. (6 mm) on the diagonal from each corner and one at the center of the faces.

8.3.2 *Width and Depth*—Average three measurements which include one taken at the center of the faces and two from the quarter points.

8.3.3 Calculate the cross-sectional area of each specimen and use to determine the precise loading per specimen.

## 9. Calibration

9.1 Calibrate each loading and measuring position separately. Follow the procedure given in Section 10 and determine the “machine output” curves for each position using a specimen of known thermal expansion. Calibration shall be done on each new furnace and after replacement of any parts of the measuring or loading devices. Fused magnesium oxide (MgO) or isostatically pressed and fired MgO of 99 % minimum purity and 3.18 g/cm<sup>3</sup> minimum bulk density is recommended for standardization. Volume-stable 90 % plus aluminum oxide (Al<sub>2</sub>O<sub>3</sub>), fused silica (SiO<sub>2</sub>), or sapphire may also be used if reliable thermal expansion data are available. Make these runs with the loading mechanism blocked so that the specimen is essentially under zero stress.

9.2 Make a minimum of three runs and record the measurements of linear change continuously with a computer/data acquisition system or on a strip chart or X-Y recorder or, if done manually, at 100 °F (55 °C) intervals up to 2000 °F (1095 °C) and 50 °F (28 °C) intervals above 2000 °F while heating in accordance with 10.5. Reposition the specimen after each run to ensure that all random errors due to handling are